

**VANTAGE  
AIR**

18865 GOLL ST. - SAN ANTONIO, TX - 78266 - ph.210-654-7171 - fax 210-654-3113

INSTALLATION INSTRUCTIONS FOR

# **MONSTER TRUNK UNIT**

**(685000-VUY)**

**COOL ONLY**

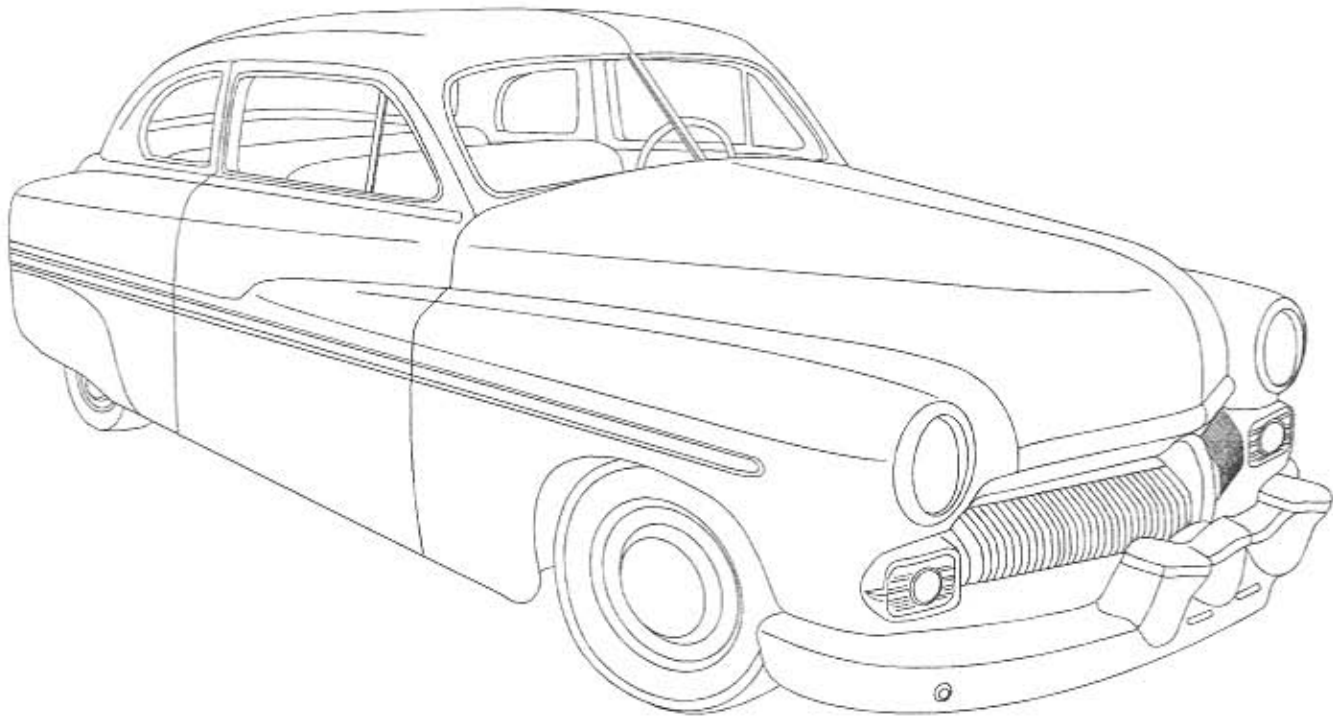

## **Table of Contents**

<u>PAGES</u>	
1.	COVER
2.	TABLE OF CONTENTS
3.	PACKING LIST
4.	INFORMATION PAGE
5.	MOUNTING/LOUVER & RETURN AIR GRILLE INSTALLATION
6.	LOUVER INSTALLATION
7.	EVAPORATOR INSTALLATION
8.	A/C HOSE ROUTING
9.	RETURN AIR GRILLE TEMPLATE
10.	LOUVER TEMPLATE
11.	THERMOSTAT PAGE
12.	WIRING DIAGRAM
13.	EVAPORATOR KIT PACKING LIST

## MONSTER TRUNK UNIT EVAPORATOR KIT PACKING LIST

**EVAPORATOR KIT  
685000-VUY**

No.	QTY.	PART No.	DESCRIPTION
1.	1	749000-VUE	MONSTER TRUNK EVAP. COOL SUB-CASE
2.	1	775000-PUN	ACCESSORY KIT

**\*\* BEFORE BEGINNING INSTALLATION OPEN ALL PACKAGES AND CHECK CONTENTS OF SHIPMENT. PLEASE REPORT ANY SHORTAGES DIRECTLY TO VINTAGE AIR WITHIN 15 DAYS. AFTER 15 DAYS, VINTAGE AIR WILL NOT BE RESPONSIBLE FOR MISSING OR DAMAGED ITEMS.**

①

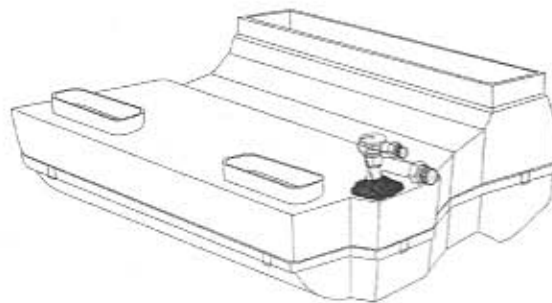

**749000-VUE  
MONSTER TRUNK  
EVAP. COOL  
SUB-CASE**

②

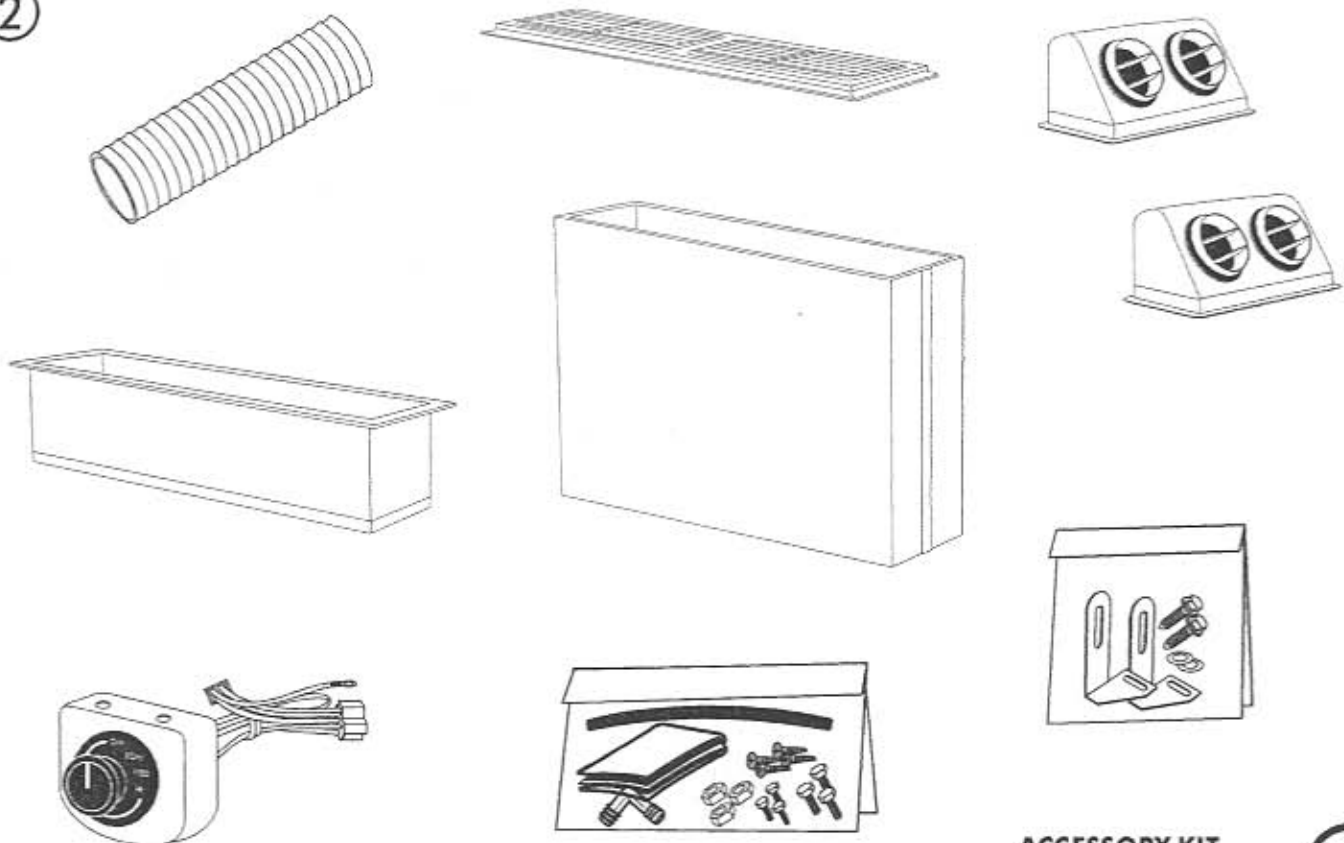

**ACCESSORY KIT  
775000-PUN**

3

## IMPORTANT NOTICE-PLEASE READ

### FOR MAXIMUM SYSTEM PERFORMANCE VINTAGE AIR RECOMMENDS THE FOLLOWING:

THIS KIT DOES NOT CONTAIN HEATER HOSE. YOU MUST PURCHASE 8 FEET OF 5/8" DIA. HEATER HOSE FROM VINTAGE AIR(31800-VUD) OR FROM YOU LOCAL PARTS RETAILER

### SAFETY SWITCHES:

YOUR VINTAGE AIR SYSTEM IS EQUIPPED WITH A BINARY PRESSURE SAFETY SWITCH. A BINARY SWITCH (11078-VUS) DISENGAGES THE COMPRESSOR CLUTCH IN CASE OF EXTREME LOW PRESSURE CONDITION (REFRIGERANT LOSS) OR EXCESSIVELY HIGH HEAD PRESSURE (380 lb.), TO PREVENT COMPRESSOR DAMAGE OR HOSE RUPTURE. A TRINARY SWITCH (11076-VUS) COMBINES HI/LO PRESSURE PROTECTION WITH AN ELECTRIC FAN OPERATION SIGNAL AT 220 lbs., AND MAY BE SUBSTITUTED FOR USE WITH ELECTRIC CONDENSER FANS. COMPRESSOR SAFETY SWITCHES ARE EXTREMELY IMPORTANT SINCE AN A/C SYSTEM RELIES ON REFRIGERANT TO CARRY LUBRICATION THROUGH THE SYSTEM.

### SERVICE INFO:

EVACUATE THE SYSTEM FOR 35-45 MINUTES WITH SYSTEM COMPONENTS (DRIER, COMPRESSOR, EVAPORATOR AND CONDENSER) AT A TEMPERATURE OF AT LEAST 85° F. ON A COOL DAY THE COMPONENTS CAN BE HEATED WITH A HEAT GUN OR BY RUNNING THE ENGINE WITH THE HEATER ON BEFORE EVACUATING. LEAK CHECK AND CHARGE TO SPECIFICATIONS.

**THE PROPER AMOUNT OF REFRIGERANT IS CRITICAL TO PROPER SYSTEM OPERATION. VINTAGE AIR RECOMMENDS OUR SYSTEMS BE CHARGED BY WEIGHT WITH A QUALITY CHARGING STATION OR SCALE.**

### REFRIGERANT CAPACITIES

#### 134a SYSTEM

CHARGE WITH 2.0 lbs. (1lbs. 12ozs) OF REFRIGERANT

#### R-12 SYSTEM

CHARGE WITH 2.2 lbs. OF REFRIGERANT

### LUBRICANT CAPACITIES

NEW COMPRESSOR - NO ADDITIONAL OIL NEEDED  
USED COMPRESSOR - CONSULT VINTAGE AIR

## INSTALLATION INSTRUCTIONS

EVERY STREET ROD IS A LITTLE DIFFERENT DEPENDING ON:

1. TYPE OF CAR, ENGINE, AND LOCATION OF ENGINE.
2. TYPE OF AIR CONDITIONING EQUIPMENT USED.
3. OWNERS MODIFICATIONS

THERE ARE MANY OTHER FACTORS THAT GO INTO MAKING EACH AIR CONDITIONING INSTALLATION DIFFERENT. TYPICALLY ALL THESE DECISIONS ARE MADE BEFORE ANY CONSIDERATION IS GIVEN TO INSTALLING AN AIR CONDITIONING SYSTEM.

**MOUNTING:** THIS IS A UNIVERSAL UNIT, PRODUCED TO FIT YOUR SPECIAL NEEDS. IT IS DESIGNED TO HAVE THE ABILITY TO COOL YOUR CAR WITH THE VERSATILITY OF BEING MOUNTED ALMOST ANYWHERE. HOWEVER PLEASE KEEP THESE POINTS IN MIND WHEN INSTALLING YOUR VINTAGE AIR EVAPORATOR KIT:

\*INSULATE CAR FOR MAXIMUM PERFORMANCE.

\*MAKE CERTAIN THERE ARE NO OBSTRUCTIONS UNDER THE FLOOR OF TRUNK WHERE EVAPORATOR WILL BE INSTALLED.  
NOTE: TEST FIT MODULE IN TRUNK TO BE CERTAIN BEFORE YOU CUT HOLES IN REAR DECK.

\*USE ALL BRACKETS TO ENSURE SOLID MOUNTING .

\*MAKE SURE EVAPORATOR IS LEVEL TO ENSURE PROPER DRAINAGE OF CONDENSATE.

### LOUVER/ RETURN AIR GRILLE INSTALLATION

- USE RETURN AIR GRILLE TEMPLATE FOR RETURN AIR PLENUM INSTALLATION. TEMPLATE ON PAGE 9.
- CENTER TEMPLATE ON THE REAR DECK WHERE YOU WANT THE RETURN AIR GRILLE PLENUM. MAKING SURE THERE ARE NO WIRES OR OBSTRUCTIONS UNDER THE REAR DECK, MARK AROUND THE TEMPLATE AND THE CUT HOLE IN REAR DECK. SEE TEMPLATE INSTRUCTIONS FIGURE 1a BELOW.
- FOR THE SIDE LOUVER ASSEMBLY'S USE THE TEMPLATE PROVIDED (SEE PAGE 10). MARK AND CUT HOLES. SEE LOUVER INSTALLATION PAGE 6.

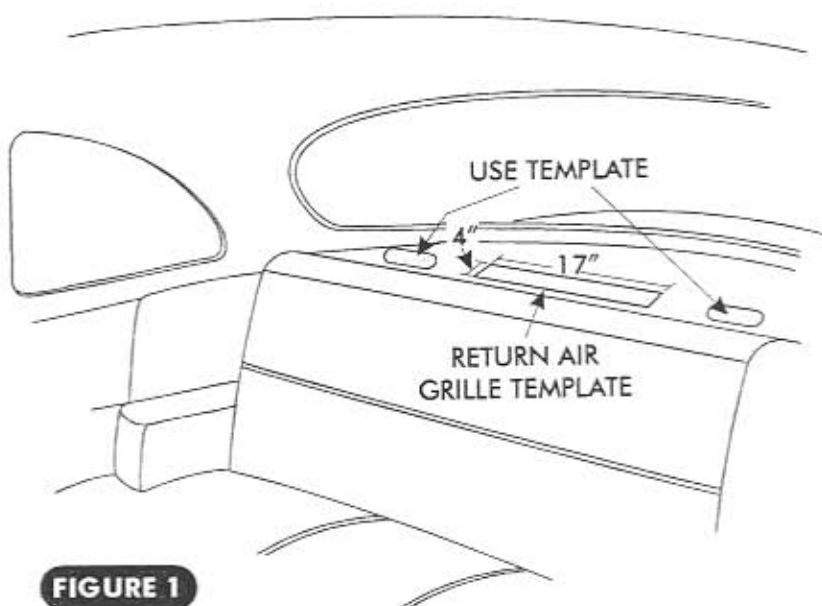

**FIGURE 1**

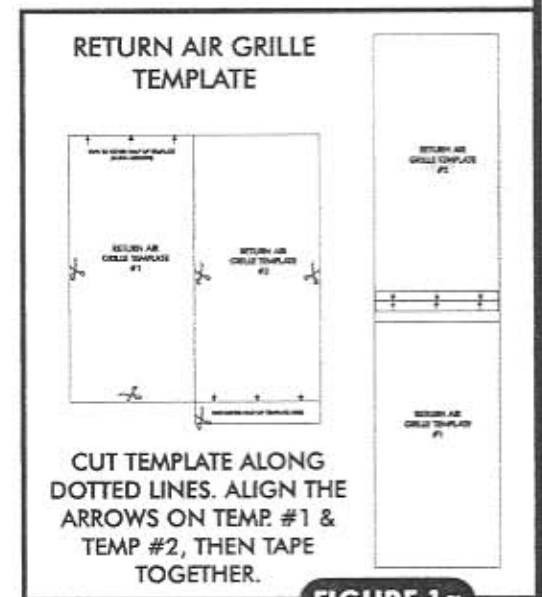

**FIGURE 1a**

### LOUVER INSTALLATION

- WITH LOUVER AND RETURN AIR HOLES CUT IN REAR DECK, ALIGN THE RETURN AIR BEZEL TOP AND MARK MOUNTING HOLES.
- USING A 1/8" DRILL BIT, DRILL PILOT HOLES IN REAR DECK.
- PLACE RETURN AIR BEZEL BOTTOM UNDER REAR DECK AND ALIGN WITH RETURN AIR BEZEL TOP (FROM ABOVE REAR DECK) AND SECURE WITH FOUR # 8 SCREWS.
- ALIGN SIDE LOUVERS AND MARK MOUNTING HOLES. DRILL PILOT HOLES WITH 1/8" DRILL BIT AND SECURE WITH #8 SCREWS. SEE FIGURE 5 BELOW.

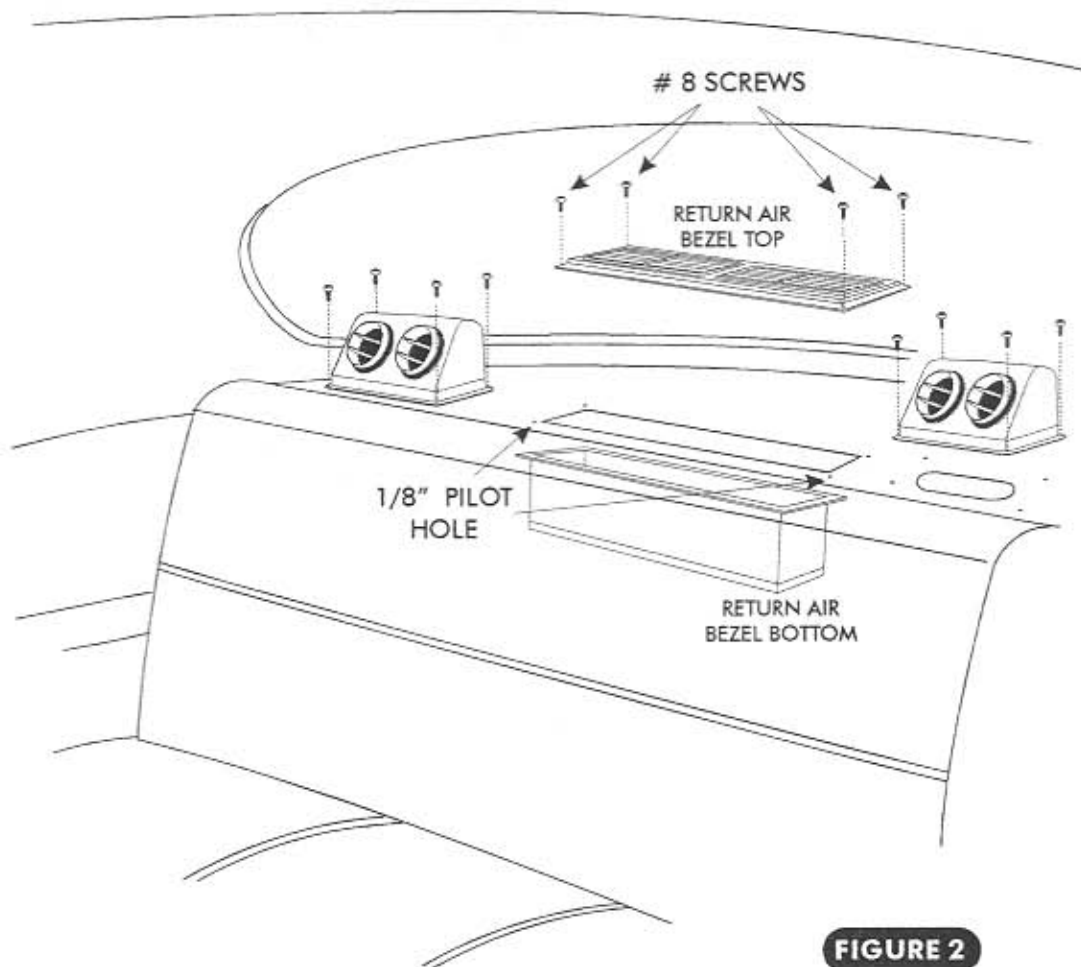

**FIGURE 2**

## EVAPORATOR INSTALLATION

- ❑ PLACE EVAPORATOR IN TRUNK AND ALIGN WITH THE RETURN AIR PLENUM IN REAR DECK. EVAPORATOR PLENUM SHOULD FIT INSIDE RETURN AIR PLENUM. TRIM HEIGHT OF EVAPORATOR PLENUM IF NEEDED.
- ❑ ONCE IN PLACE AND CERTAIN THERE ARE NO OBSTRUCTIONS UNDER THE FLOOR OF TRUNK, MARK THE MOUNTING HOLES THROUGH BRACKETS. SEE FIGURE 2, BELOW .
- ❑ WITH THE EVAPORATOR OUT OF THE WAY, USE A 1/8" DRILL BIT AND DRILL PILOT HOLES IN FLOOR OF TRUNK.
- ❑ ALIGN THE EVAPORATOR WITH HOLES IN TRUNK AND SECURE WITH (2) #10 x 1" SHEET METAL SCREW AND WASHER PROVIDED.
- ❑ SECURE PLENUMS TO EVAPORATOR SUB-CASE USING 8 x 1/2" SCREWS. SEE FIGURE 3 BELOW.

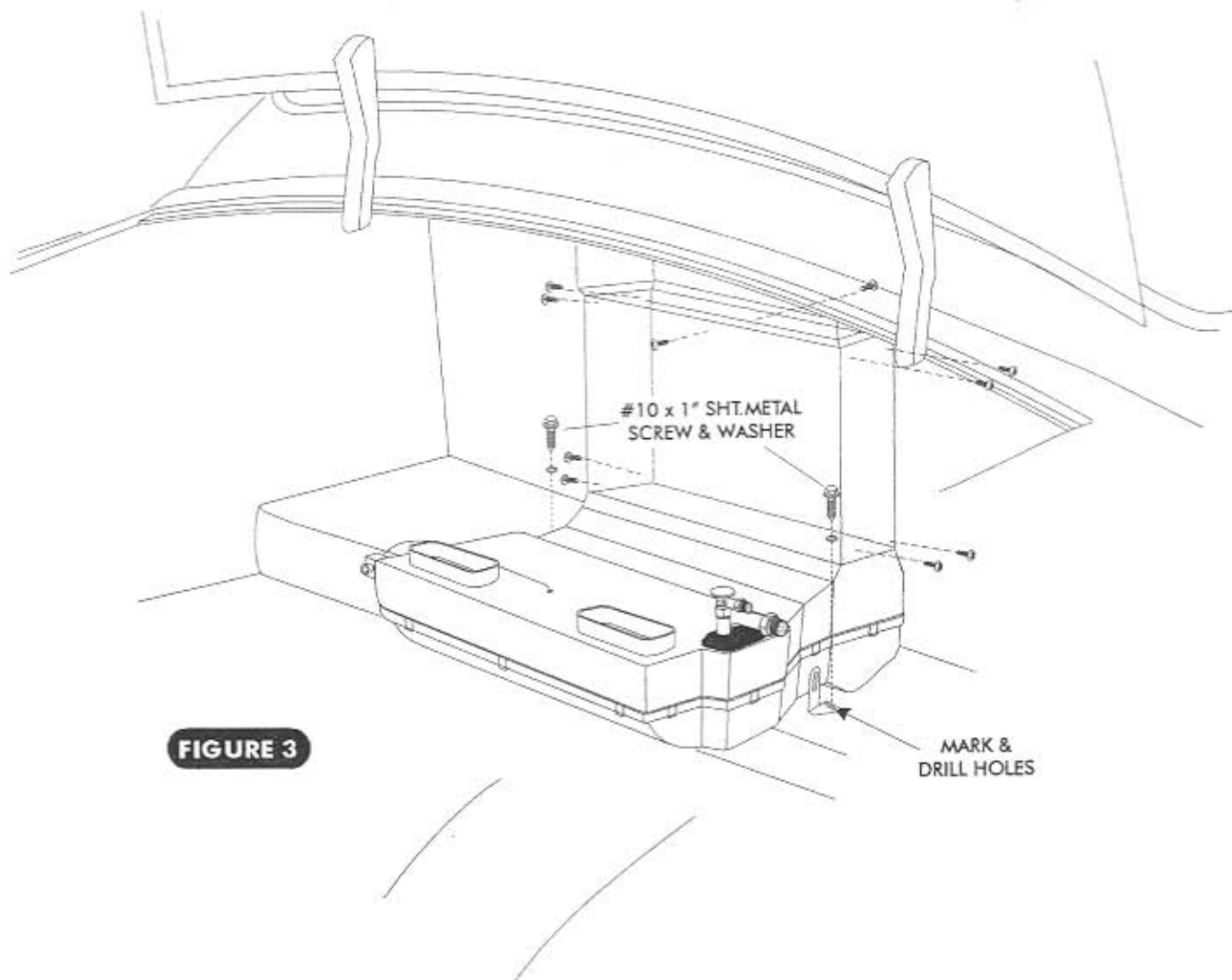

**FIGURE 3**

**A/C HOSE ROUTING**

**PLANNING YOUR HOSE ROUTING:**

- MOUNT ALL MAJOR AIR CONDITIONING COMPONENTS: EVAPORATOR, COMPRESSOR, CONDENSER, AND DRIER. *NOTE: THE EVAPORATOR MUST BE MOUNTED IN PLACE TO ROUTE HOSES.*
- AT THIS TIME YOU MUST DETERMINE THE ROUTING OF YOUR A/C HOSES. SEE FIGURE 5 BELOW. ALSO YOU MUST DECIDE HOW YOU WILL SECURE THE HOSES IN PLACE (CLAMPS, BRACKETS, ETC.). MAKE SURE HOSES THAT PASS THROUGH THE FENDER WELL, FIREWALL, OR NEXT TO SHARPE EDGES ARE PROTECTED.

*NOTE: WHEN DETERMINING THE HOSE ROUTING, KEEP IN MIND IF YOU PASS HOSES TROUGH THE SIDE PANEL OR FLOOR OF THE TRUNK THAT THEY ARE CLEAR OF OBSTRUCTIONS BEFORE YOU DRILL HOLES.*

- ONCE YOU HAVE DECIDE ON THE HOSE ROUTING AND THE PROPER FITTINGS, TEST FIT ALL HOSES.
- WHEN YOU ARE READY FOR FINAL HOSE INSTALLATION, YOU MUST LUBRICATE O-RINGS AND TIGHTEN ALL FITTING. SEE FIGURE 4 BELOW.

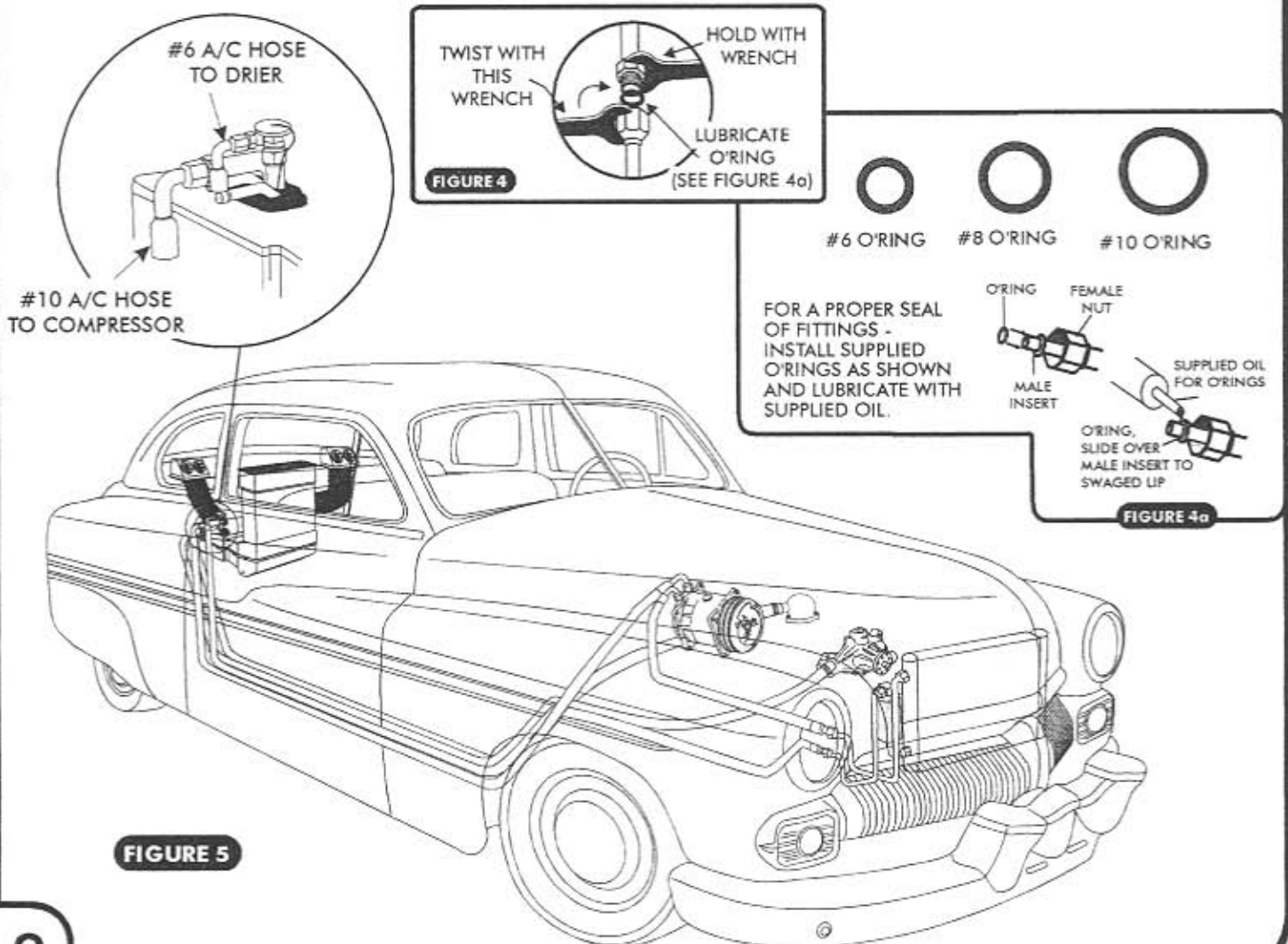

**FIGURE 5**





TAPE TO OTHER HALF OF TEMPLATE  
(ALIGN ARROWS)

RETURN AIR  
GRILLE TEMPLATE  
#1

RETURN AIR  
GRILLE TEMPLATE  
#2



TAPE OTHER HALF OF TEMPLATE HERE



**FINAL STEPS**

- INSTALL CONTROL PANEL AND WIRE ACCORDING TO WIRING DIAGRAM ON PAGE 11.
- SELECT A SUITABLE LOCATION FOR THE CONTROL PANEL. CONSIDER THE LENGTH OF THE WIRING HARNESS. THE PANEL MAY BE MOUNTED UNDER THE DASH, OR THE SWITCH CAN BE REMOVED AND INSTALLED IN DASH. SEE FIGURE 6.
- REINSTALL ALL PREVIOUSLY REMOVED ITEMS (BATTERY BOX, BATTERY & INTERIOR PANELS ETC.).

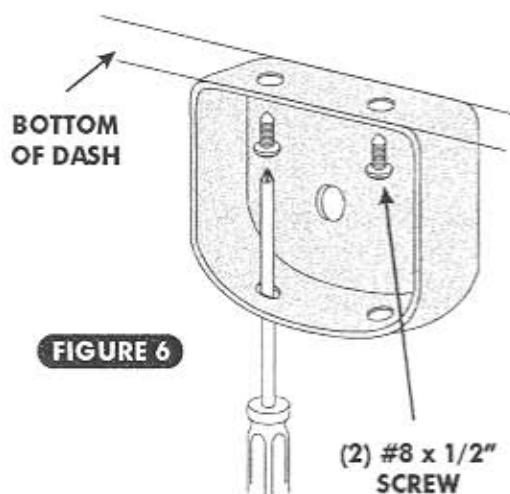
**FIGURE 6**

- FILL RADIATOR WITH AT LEAST A 50/50 MIXTURE OF APPROVED ANTIFREEZE AND WATER. IT IS THE OWNER'S RESPONSIBILITY TO KEEP THE FREEZE PROTECTION AT THE PROPER LEVEL FOR THE CLIMATE IN WHICH THE VEHICLE IS OPERATED. FAILURE TO FOLLOW ANTIFREEZE RECOMMENDATIONS WILL CAUSE HEATER CORE TO CORRODE PREMATURELY AND POSSIBLY BURST IN AC MODE AND/OR FREEZING WEATHER, VOIDING YOUR WARRANTY.
- DOUBLE CHECK ALL FITTINGS, BRACKETS AND BELTS FOR TIGHTNESS.
- VINTAGE AIR RECOMMENDS THAT ALL AC SYSTEMS BE SERVICED BY A CERTIFIED AUTOMOTIVE AIR CONDITIONING TECHNICIAN.
- EVACUATE THE SYSTEM FOR A MINIMUM OF 45 MINUTES PRIOR TO CHARGING AND LEAK CHECK PRIOR TO SERVICING.
- CHARGE THE SYSTEM TO THE CAPACITIES STATED ON THE INFORMATION PAGE (PAGE 4) OF THIS INSTRUCTION MANUAL.

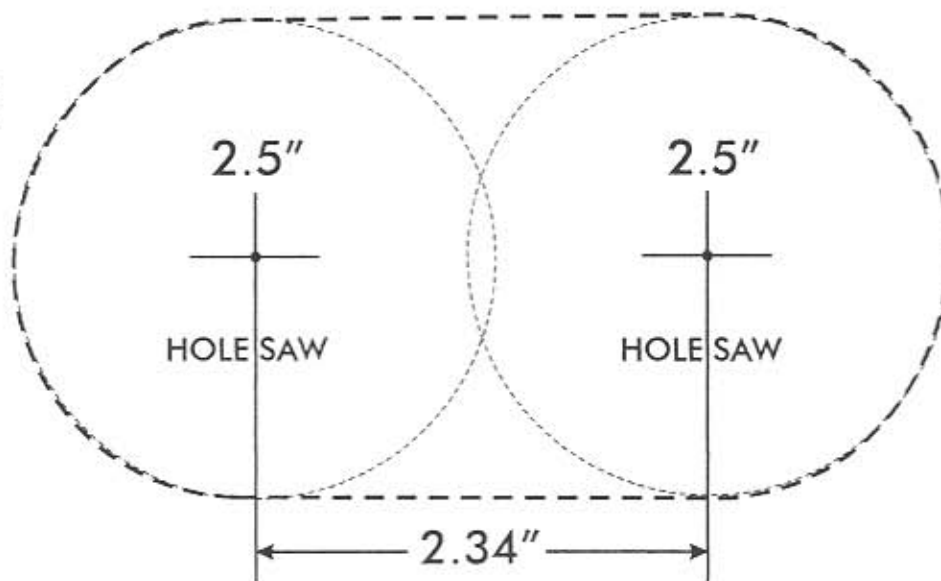
**LOUVER  
TEMPLATE**

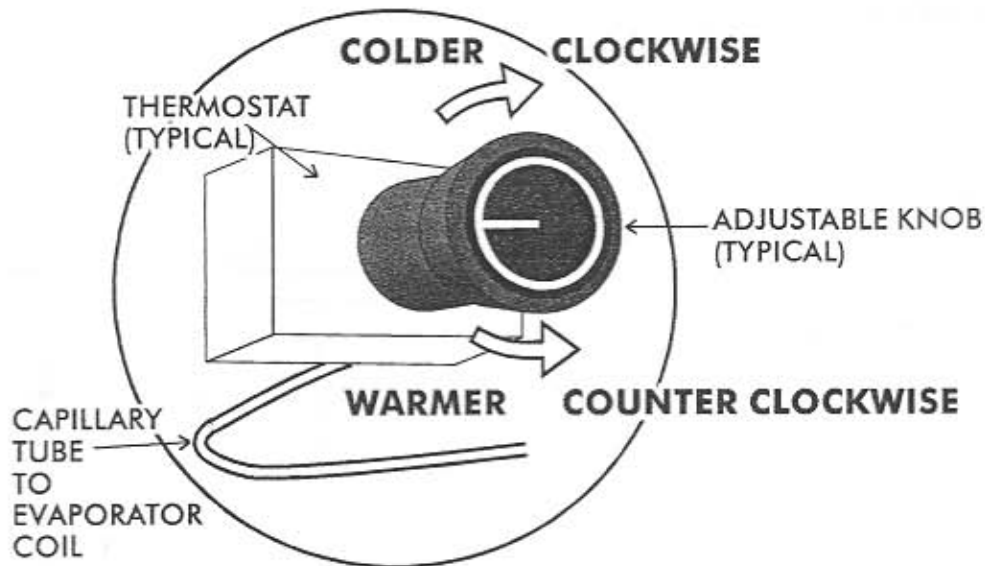

## AIR CONDITIONING ADJUSTMENTS:

- THE AIR CONDITIONER THERMOSTAT CONTROLS COIL TEMPERATURE, IT IS SHIPPED ADJUSTED FULLY COLD (CLOCKWISE), IN THE MAJORITY OF CASES THE A/C WILL OPERATE CORRECTLY AS SHIPPED.
- TURNING THE KNOB ON THE THERMOSTAT TO THE RIGHT (CLOCKWISE) MAKES THE SYSTEM OPERATE COLDER. IF THE THERMOSTAT IS SET TOO COLD THE EVAPORATOR WILL "ICE UP" - THE EVAPORATOR COIL IS RESTRICTED WITH ICE AND COLD AIR FLOW WILL BE REDUCED.
- TURNING THE KNOB TO THE LEFT (COUNTER CLOCKWISE) MAKES THE SYSTEM OPERATE WARMER. THE COMPRESSOR CLUTCH WILL CYCLE OFF FREQUENTLY AND THE A/C SYSTEM WILL NOT GET AS COOL AS IT COULD.

## ADJUSTING A/C THERMOSTAT

1.) **SYMPTOM:** THE A/C WORKS WELL AT FIRST THEN QUILTS COOLING. THE AIR FLOW FROM THE VENTS IS LOW AND THE COMPRESSOR CYCLES INFREQUENTLY.

**SOLUTION:** THE THERMOSTAT IS SET TOO COLD AND THE EVAPORATOR IS "ICING UP" AND RESTRICTING AIR FLOW. ALLOW THE ICE TO MELT AND SET THE THERMOSTAT WARMER (COUNTER CLOCKWISE) 10% OF A TURN EACH ADJUSTMENT UNTIL THE SYMPTOMS DIMINISH.

2.) **SYMPTOM:** A/C NEVER GETS COLD AND THE COMPRESSOR CLUTCH CYCLES FREQUENTLY.

**SOLUTION:** THE THERMOSTAT IS SET TOO WARM. SET THE THERMOSTAT COLDER (CLOCKWISE) 10% OF A TURN EACH ADJUSTMENT UNTIL THE COMPRESSOR CLUTCH CYCLES INFREQUENTLY. AVOID SETTING THE THERMOSTAT TOO COLD.

3.) **SYMPTOM:** THE A/C NEVER GETS COLD, SOMETIMES EVEN BLOWS HOT, AND THE A/C COMPRESSOR CLUTCH INFREQUENTLY CYCLES OFF.

**SOLUTION:** THE HEATER MAY BE ON AT ALL TIMES. CAREFULLY FEEL AROUND THE HEATER HOSES AT THE FIREWALL. THEY SHOULD BE COLD WHEN THE A/C IS ON. IF THE HOSES ARE HOT....

- A) - THE HEATER CONTROL VALVE MAY BE INSTALLED BACKWARDS. CHECK THE FLOW DIRECTION ARROW ON THE VALVE AGAINST THE ILLUSTRATION IN YOUR INSTALLATION INSTRUCTIONS.
- B) - CABLE OPERATED: THE VALVE MAY BE MISADJUSTED.
- C) - HEATER CONTROL VALVE IS INSTALLED IN WRONG HEATER HOSE.

**WIRING DIAGRAM**  
COOL

(OPTIONAL) COMPRESSOR  
SAFETY SWITCH  
(BINARY TYPE)  
V.A. #24677-VUS

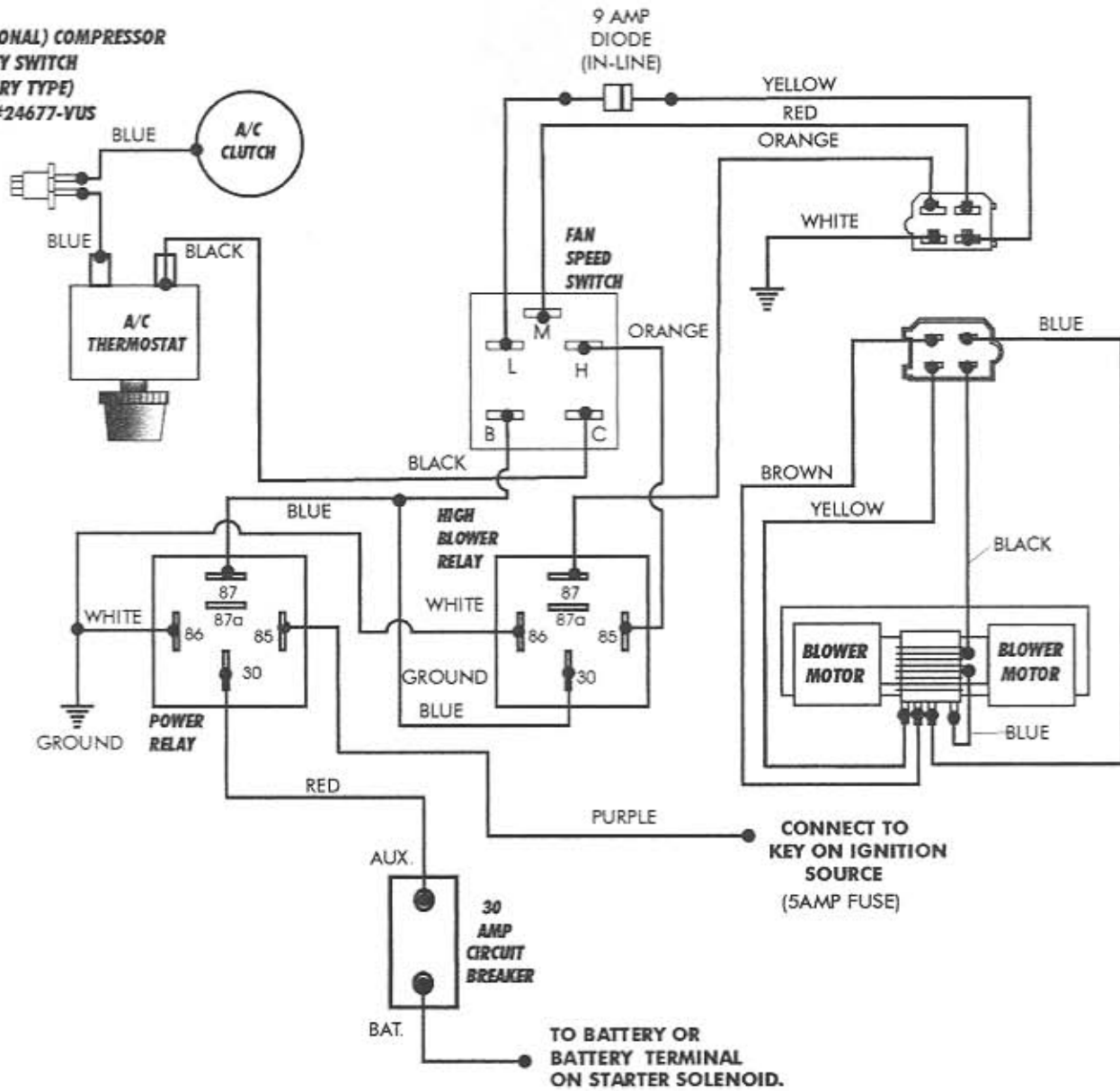

**MONSTER TRUNK UNIT  
EVAPORATOR KIT PACKING LIST**
**EVAPORATOR KIT  
685000-VUY**

No.	QTY.	PART No.	DESCRIPTION
1.	1	749000-VUE	MONSTER TRUNK EVAP. COOL SUB-CASE
2.	1	775000-PUN	ACCESSORY KIT

 CHECKED BY: \_\_\_\_\_  
 PACKED BY: \_\_\_\_\_  
 DATE: \_\_\_\_\_

①

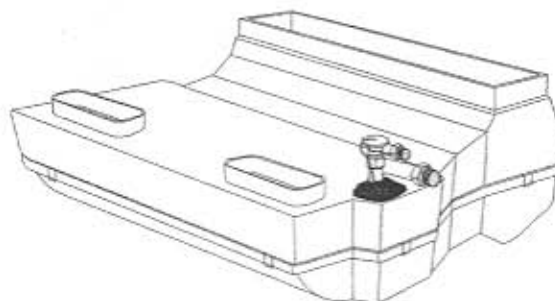
**749000-VUE  
MONSTER TRUNK  
EVAP. COOL  
SUB-CASE**

②

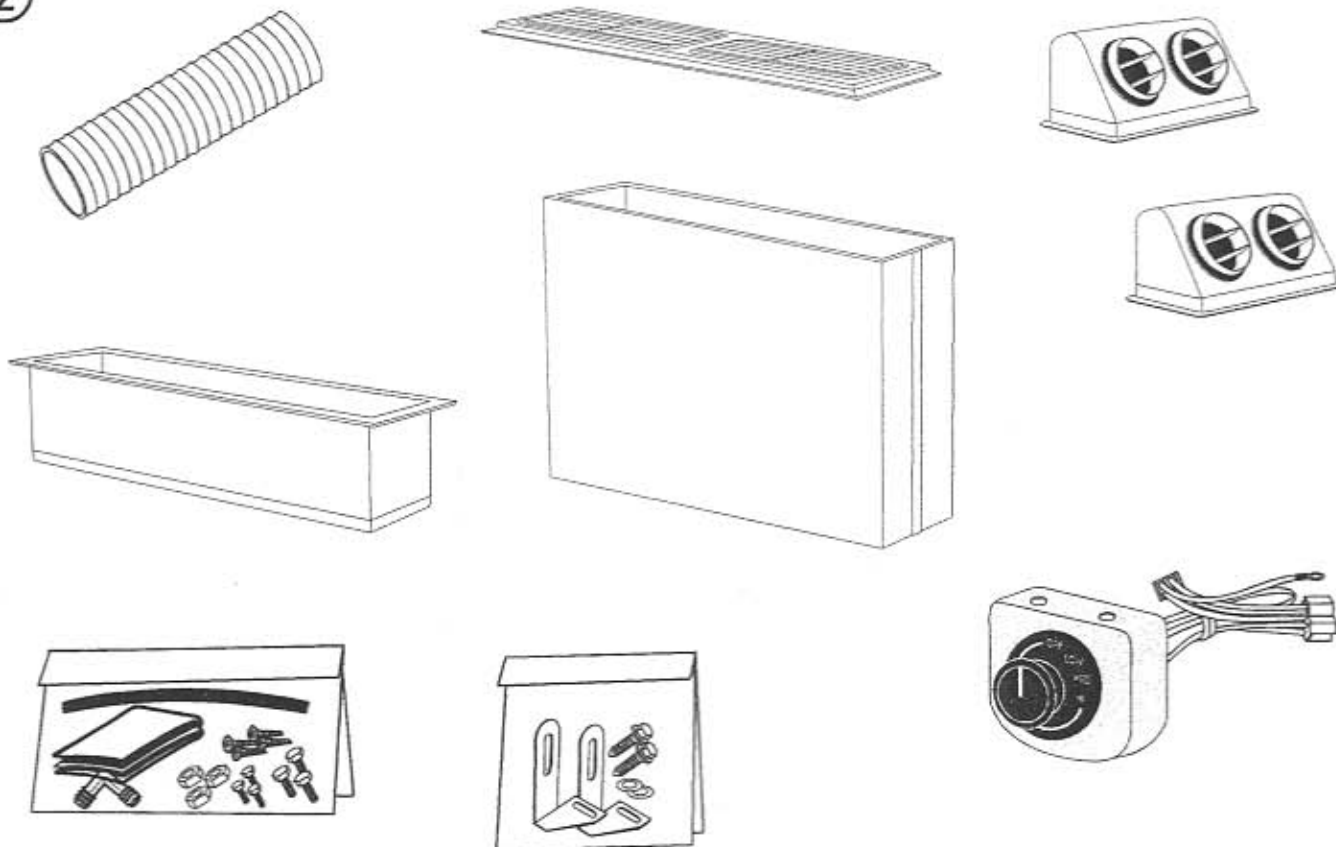
**ACCESSORY KIT  
775000-PUN**